

## VHF Transmitter Family R&S NM/NW7001

### Air-cooled transmitters for analog and digital TV (DVB-T or ATSC)

- ◆ 250 W to 2 kW output power for analog TV
- ◆ 200 W to 800 W output power for DVB-T
- ◆ 200 W to 1200 W output power for ATSC
- ◆ Compact standardized 19" rack with integrated fans
- ◆ Ambient-air or forced-air cooling
- ◆ High redundancy
- ◆ Highly service-friendly due to modular design and plug-ins
- ◆ Digital exciter
- ◆ Integrated OFDM coder or 8VSB coder (with R&S NW7001)
- ◆ Advanced MOSFET technology for power amplifiers
- ◆ Optional second exciter for passive standby configuration
- ◆ Exciter, amplifier technology and transmitter control unit identical to liquid-cooled Transmitters R&S NM/NW7000

## At a glance

With Transmitter Family R&S NM/NW7001 Rohde & Schwarz has extended the generation of transmitters for medium power based on MOSFET transistors. These air-cooled transmitters are suitable for analog and digital TV (DVB-T or ATSC).

The transmitters consist of the following components:

- ◆ Exciter
- ◆ Power amplifiers
- ◆ Power supply
- ◆ Transmitter rack

The VHF transmitters are available for analog TV with powers of 250 W to 2 kW (combined) and for digital TV with powers of 200 W/300 W to 800 W/1200 W.

The power amplifiers come as plug ins with a power of 500 W for analog TV or 200 W/300 W for digital TV. This means high flexibility regarding output power and redundancy. Each amplifier module has its own power supply.

The newly developed exciter is an unrivalled innovation since signal processing is digital for analog TV signals too. The difference between the variants for analog TV, DVB-T and ATSC is simply the encoder module. Retrofitting a transmitter from analog to digital TV is thus very simple.

In addition, the exciter is extremely compact which permits the integration of a second exciter and the associated automatic switchover unit in all transmitters. The following standby systems are available:

- ◆ Exciter standby
- ◆ Passive standby transmitter
- ◆ Exciter standby with active output stage standby
- ◆ n+1 standby

Moreover, the Transmitter Family R&S NM/NW7001 offers a variety of options for remote control such as parallel interface, SNMP interface or the linkup via an integrated Web server.



## Exciter

The new exciter comprises the following modules:

- ◆ Encoder for analog TV, DVB-T or ATSC
- ◆ Digital precorrector
- ◆ Modulator
- ◆ Synthesizer
- ◆ Central control unit
- ◆ Control unit
- ◆ Motherboard
- ◆ Power supply

### Analog mode

The encoder for analog TV first converts the video and audio input signals to the digital form. The processing of these signals according to the associated TV or colour coding standard is digital which provides for high stability and easy correction.

The encoder uses digital filters to convert the processed video signal and the sound subcarriers separately for signal display with inphase and quadrature signal.

### DVB-T mode

The encoder for DVB-T is integrated in a single module. It has two physical ASI interfaces which form a complete processing path (input interface, FEC and delay). For non-hierarchical coding the two paths can be selected as a main and a standby path.

The encoder can be used both in multi-frequency networks and single-frequency networks. For single-frequency networks a GPS receiver is integrated. In the event of loss of the GPS signal, the oven-controlled crystal oscillators are stable enough for the DVB-T transmitter to continue operation in the single-frequency network for a specific period of time.

A MIP decoder in line with TS101191 is available for the two processing paths and allows automatic delay compensation as well as automatic mode setting.

Channel coding and modulation are performed according to EN 300744. The channel bandwidths of 6 MHz, 7 MHz and 8 MHz are supported.

### ATSC mode

The ATSC encoder module comprises data randomizer, Reed-Solomon encoder, data interleaver, Trellis encoder, MUX and pilot insertion. Channel coding and modulation are in line with Doc. ATSC-A53.



All versions of the encoder transfer the digital inphase and quadrature signals with a resolution of 12 bit to the digital precorrector. The precorrector is divided into two sections:

- ◆ The group-delay equalizer can compensate the group delay which occurs, for example, in power filters or vision/sound diplexers.
- ◆ The linearity precorrector can precorrect the instantaneous signal amplitude and phase.

Since the precorrection is digital, the reproducibility is 100% even if modules are replaced.

In the case of DVB-T, the signal can be conditioned after the linearity precorrector to limit the crest factor. The I and Q signals are then converted to the analog domain.

The I/Q modulator converts the baseband signals to the VHF frequency by means of direct modulation. Settable filters suppress unwanted mixer products. The signals are next amplified so that the output stage can be directly driven without an additional amplifier.

The synthesizer delivers the local frequency (VHF) to the I/Q modulator for direct modulation. It provides a setting stepwidth of 1 Hz and thus supports precision-offset operation. The connection to an external frequency of 1 MHz or 10 MHz or to an integrated GPS module (option) is possible.

The central control unit accommodated in the exciter rack ensures the control and monitoring of the whole transmitter. This central control unit enables the user to access the parameters of the whole system, in particular those of the integrated encoders, via the control panel. In this way, only one remote control interface is required to monitor all functional units of the transmitter.

The program code of all programmable exciter components is stored in a flash EPROM. Thus the software can be updated from a PC via a service interface (RS232) by means of a download routine.

## Power amplifiers and power supplies

Thanks to advanced MOSFET technology, the power amplifiers are characterized by high linearity, high efficiency and compact design. Each amplifier plug-in contains a pre-driver, a driver and two or four output stages.

Each amplifier has built-in monitoring (self-protection) ensured by its own RF output power control. The integrated preamplifier contains a phase correction for the RF output power as well as the output power control in addition to monitoring and evaluation of protective functions such as overtemperature switch-off, VSWR reduction, transistor failure recognition, etc. The output power control prevents, for example, the amplifier from being overdriven in case of a transistor failure. This ensures long lifetime of the individual transistors. In normal operation the transistors reach a junction temperature of 120 °C only which also contributes to a long lifetime. The amplifier modules can be replaced easily during transmitter operation.

Each amplifier plug-in is fed by a separate power supply, and each plug-in forms a self-contained mechanical unit. Thus redundancy for the supply voltages of the amplifiers is ensured. The power supplies are designed for one supply voltage only. This reduces transmitter rack cabling and thus enhances operational reliability. The amplifiers internally generate all the other voltages they require, which again makes for redundancy. The power supply is designed as a three-phase, short-circuit-proof, primary-switched regulator. The power supplies can be replaced during operation without interrupting the running program by undoing the plug-and-socket connection.

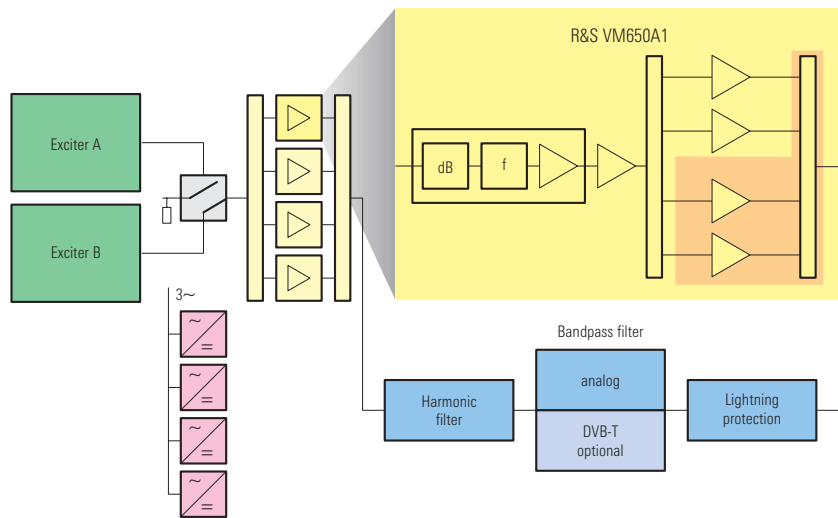

**Block diagram**

## Transmitter rack

A standardized 19" rack (800 mm deep) is used for all power classes.

Up to four amplifier modules and power supplies can be integrated in one rack.

Depending on the output power, a 2-, 3- or 4-fold coupler is provided on the rear panel.

The connectors for modulation lines (VF, AF or TS), for example, as well as the remote control interface etc are located on the top of the transmitter rack.

The transmitter rack contains two fans. Air can be taken from and to the transmitter room or from and to the outside. Air ducts are provided at the bottom and top of the transmitter rack, which speaks for the outstanding flexibility and service-friendliness of Transmitter Family R&S NM/NW 7001.

Certified Quality System  
**ISO 9001**  
DQS REG. NO 1954

Certified Environmental System  
**ISO 14001**  
REG. NO 1954

# Specifications

## Specifications common to R&S NM/NW7001

<b>Frequency range</b>	170 MHz to 250 MHz
Power supply	3 x 400 V AC +/-10%, three-phase operation
Max. installation altitude	2000 m above sea level (>2000 m on request)
Operating temperature range	+4°C to +45°C
Permissible relative air humidity	95%, non condensing
Dimensions (W x H x D) in mm	582 x 2034 x 800
RF connectors	1 5/8 EIA

<b>Inputs</b>	
Analog	2 x video (BNC, 75 Ω) 2 x sound (XLR, 3-contact)
DVB-T	2 x ASI (in pairs)
ATSC	2 x SMPTE-310 (BNC, 75 Ω)

<b>Interfaces</b>	
RS-232	at the front, operation of transmitter by means of graphical user interface (GUI) from PC, sub-D, female, 9-contact
RS-485	for remote control of transmitter, at transmitter top, sub-D, female, 9-contact
RS-232	for remote control of transmitter, at transmitter top, sub-D, female, 9-contact (connection of Hayes-compatible modem)

<b>Optional</b>	parallel remote-control interface, floating, for messages and commands; SNMP interface or/and TCP/IP-WEB server
-----------------	---

## Specification R&S NM7001 (Analog TV)

	R&S NM 7005	R&S NM 7010	R&S NM 7015	R&S NM 7020
RF output power	500 W	1 kW	1.5 kW	2 kW
RF power of plug-in modules	1 x 500 W	2 x 500 W	3 x 500 W	4 x 500 W
Number of power supplies	1	2	3	4
Air throughput	20 m <sup>3</sup> /min			
Reference frequency	1 MHz, 5 MHz or 10 MHz, 0.1 V to 5 V (V <sub>pp</sub> ) or TTL, BNC			

TV standards	B, G, D, K, M, N, I
Colour transmission	PAL, NTSC, SECAM
Sound transmission	two-tone coding to IRT or FM single sound and NICAM728 (-13 dB / -20 dB) or FM single sound (-10 dB)

## Specification R&S NW7001 (DVB-T/ATSC)

	R&S NW 7021	R&S NW 7041	R&S NW 7061	R&S NW 7081
RF output power DVB-T	200 W	400 W	600 W	800 W
RF output power ATSC	300 W	600 W	800 W	1200 W
RF power of plug-in modules	1 x 200 W/300 W	2 x 200 W/300 W	3 x 200 W/300 W	4 x 200 W/300 W
Number of power supplies	1	2	3	4
Air throughput	20 m <sup>3</sup> /min			
Reference frequency	1 MHz, 5 MHz or 10 MHz, 0.1 V to 5 V (V <sub>pp</sub> ) or TTL, BNC			
Reference pulse	1 Hz, TTL, BNC			

<b>DVB-T</b>	
Coding and modulation according to EN 300744	
IFFT mode	2 k and 8 k
Useful symbol period	224 μs (2 k) or 896 μs (8 k)
Modulation	QPSK, 16QAM or 64QAM
Guard interval	1/4, 1/8, 1/16 or 1/32 of useful symbol period
Inner code rate	1/2, 2/3, 3/4, 5/6 or 7/8

<b>ATSC</b>	
according to Doc. A53/1995	
Modulation	8VSB
Symbol rate	10.76 MHz
Data rate	19.39 Mbit/s
Trellis coding	2/3
Reed-Solomon encoder	207/187/10



ROHDE & SCHWARZ GmbH & Co. KG · Mühlendorfstraße 15 · 81671 München · Germany · P.O.B. 80 14 69 · 81614 München · Germany · Telephone +49 89 4129-0  
www.rohde-schwarz.com · Customer Support: Telephone +49 1805124242, Fax +49 89 4129-13777, E-mail: CustomerSupport@rohde-schwarz.com